



OPTIMUM DESIGN AT POINTS OF REINFORCED CONCRETE SLABS USING MATHEMATICAL PROGRAMMING

ALEXANDRE MIRANDA MONT'ALVERNE

Department of Mechanical Engineering, Federal University of Ceará (UFC), Center of Technology, Pici Campus, Block 714, Fortaleza, CE, ZIP CODE 60455-760, Brazil. E-mail: miranda@dem.ufc.br, miranda@cenapadne.br

LUIZ ELOY VAZ

Department of Civil Engineering, Pontifical Catholic University of Rio de Janeiro (PUC-Rio), Rio de Janeiro, RJ, ZIP CODE 22453-900, Brazil. E-mail: eloy@civ.puc-rio.br

MARTA DE SOUZA LIMA VELASCO

Department of Civil Engineering, Pontifical Catholic University of Rio de Janeiro (PUC-Rio), Rio de Janeiro, RJ, ZIP CODE 22453-900, Brazil. E-mail: marta@civ.puc-rio.br

Abstract. *The optimum design is made for each point of the slab in function of the resultants forces applied at the point. The determination of the resultants forces is made by the finite element method with the hypothesis of linear elastic behavior. In the reinforced concrete slabs the design should guarantee that at any point of the slab the resultants forces be located on or inside the adopted yield surface. The yield surface is defined in function of the positive and negative ultimate moments corresponding to the directions of the orthogonal reinforcement of the slab. The ultimate resistant moments should be greater than every resultants moment so that the yield surface includes these moments. The optimum design is made using mathematical programming. The optimum design problem is solved by the Interior Points Method algorithm (Herskovits, 1995). The optimum design program uses the yield criterion proposed by Johansen (1962) and later on corrected by Velasco et al. (1994). This article proposes a method of optimum design at points of reinforced concrete slabs with orthogonal reinforcement, based on the yield criterion proposed by Velasco et al. (1994).*

Key-words: *Reinforced concrete slabs, Finite element method, Mathematical programming*

1. INTRODUCTION

Before introducing the method of optimum design of reinforced concrete slabs proposed in this article, it is necessary to make clear that the design method used for the calculation of the resistant efforts should be compatible with the analysis model used for the calculation of resultants forces, that is to say, the slab should be designed for all the resultants forces that the analysis model supplies. Models that better reproduce the reality drive, in general, to a

more appropriate reinforcement rate taking to a better description of the structure behavior. The analysis models based on the theory of plates generally supply three moments at any point of the slab: two moments of flexion m_x and m_y , along the x and y axes respectively, and a moment of torsion m_{xy} . When the analysis model considers the moment of torsion, the design becomes more complex. In this case, it becomes indispensable to do the design taking into consideration the existence of the moment of torsion, otherwise we will totally going against safety. Today in the project of complex structures of reinforced concrete the finite element method is used for the resultants forces numeric analysis driving, so, to projects that better represent the reality. In this article, a formulation is presented for the optimum design of reinforced concrete slabs using elastic-linear analysis in plates of flexion by the finite element method and mathematical programming. The yield criteria proposed by Johansen (1962) and later on corrected by Velasco *et al.* (1994), both used in the optimum design, are an specific application for the reinforced concrete slabs. The yield criterion proposed by Velasco *et al.* (1994) has as objective the correction of the yield criterion proposed by Johansen usually used in the determination of the ultimate resistance of reinforced concrete slab. The Interior Points Method algorithm (Herskovits, 1995) is used by the first time in the optimum design at points of reinforced concrete slabs.

This article proposes a method of optimum design at points of reinforced concrete slab with orthogonal reinforcement, based on the yield criterion proposed by Velasco.

2. YIELD CRITERION

The yield criterion is characterized by an yield surface, defined as the geometric locus of the stresses tensor independent combinations components or of the independent combinations stresses resultants that provoke the material plastification. Mathematically the yield surface can be defined by the expression presented as follows:

$$\pi(\sigma) = 0 \quad (1)$$

The postulates of the plasticity define the yield surface as a continuous, convex area which could be regular or not.

The yield surfaces implemented in this work were proposed by Johansen (1962) and Massonet *et al.* (1972) and by Velasco *et al.* (1994), and are of specific application for reinforced concrete slabs.

2.1 Yield criterion of Johansen

According to Johansen, the yield condition is based on the following physical criterion proposed by Massonet *et al.* (1972): “The yield happens when the applied moment of flexion in a cross-section of inclination θ in relation to the x axis reaches a certain value that just depends on the angle θ and on the resistant moments in the reinforcement directions.” The basic parameters of the Johansen criterion are presented as follows:

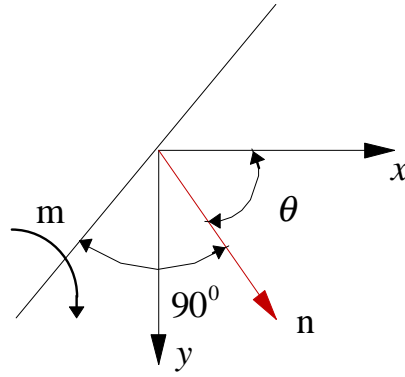

Figure 1 - Basic parameters of the Johansen criterion.

Yield surface of Johansen. The yield surface proposed by Johansen is frequently used to determine the ultimate resistance in the project and design of reinforced concrete slabs (Johansen, 1962) and (Massonet *et al.*, 1972). The mathematical equations that define this surface are presented as follows.

$$\pi 1(\sigma) = m_{xy}^2 - (M_{px}^+ - m_x) \times (M_{py}^+ - m_y) = 0 \quad (2)$$

$$\pi 2(\sigma) = m_{xy}^2 - (M_{px}^- + m_x) \times (M_{py}^- + m_y) = 0 \quad (3)$$

Where, M_{px}^+ , M_{py}^+ , M_{px}^- and M_{py}^- are respectively the positive and negative plastification moments by unit of length in the x and y directions.

The Equation (2) is associated to the positive yield line and Eq. (3) is associated to the negative yield line.

The Equations (2) and (3) represent two conical surfaces that combined define the yield surface of Johansen. The surface of Johansen is presented as follows:

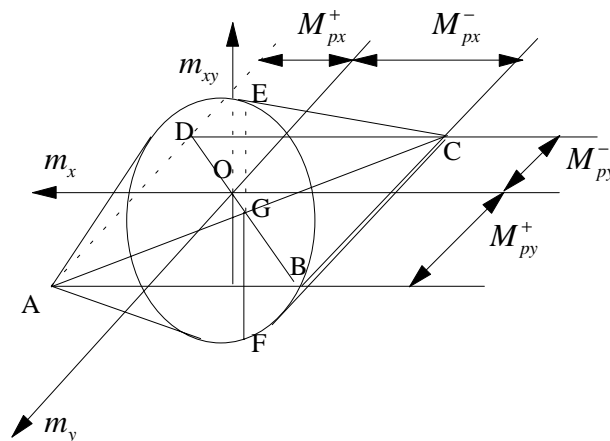

Figure 2 – Yield surface of Johansen.

2.2 Yield criterion of Velasco

This surface is proposed by Velasco *et al.* (1994) with objective of correcting the yield surface of Johansen usually used in the determination of the ultimate resistance of the reinforced concrete slabs. According to recent researches, the yield surface of Johansen overestimates the resistance of the slab in pure torsion (Marti *et al.*, 1987). Base on experimental and numeric results it is necessary to correct the surface of Johansen in the case where the moment of torsion possesses significant values in relation to the moments of flexion and when a high reinforcement rate is used.

Yield surface of Velasco. The equations that represent the surface proposed by Velasco are presented as follows:

$$\pi 1(\sigma) = m_{xy}^2 - (M_{px}^+ - m_x) \times (M_{py}^+ - m_y) = 0 \quad (4)$$

$$\pi 2(\sigma) = m_{xy}^2 - (M_{px}^- + m_x) \times (M_{py}^- + m_y) = 0 \quad (5)$$

$$\pi 3(\sigma) = m_{xy}^2 \{ (M_{px}^+ + M_{py}^+) - (m_x + m_y) \}^2 - (M_{px}^+ - m_x)(M_{py}^+ - m_y) \times \frac{4M_{px}^+ M_{py}^+}{(k_{xy}^+)^2} = 0 \quad (6)$$

$$\pi 4(\sigma) = m_{xy}^2 \{ (M_{px}^- + M_{py}^-) + (m_x + m_y) \}^2 - (M_{px}^- + m_x)(M_{py}^- + m_y) \times \frac{4M_{px}^- M_{py}^-}{(k_{xy}^-)^2} = 0 \quad (7)$$

Where:

$$k_{xy}^+ = (1 + 4(w_x^+)^2) \times (1 + 4(w_y^+)^2); \quad k_{xy}^- = (1 + 4(w_x^-)^2) \times (1 + 4(w_y^-)^2) \quad (8)$$

$$\rho_x^+ = \frac{a_x^+}{h}; \quad \rho_y^+ = \frac{a_y^+}{h}; \quad \rho_x^- = \frac{a_x^-}{h}; \quad \rho_y^- = \frac{a_y^-}{h} \quad (9)$$

$$w_x^+ = \frac{\rho_x^+ f_y}{f_c}; \quad w_y^+ = \frac{\rho_y^+ f_x}{f_c}; \quad w_x^- = \frac{\rho_x^- f_y}{f_c}; \quad w_y^- = \frac{\rho_y^- f_x}{f_c} \quad (10)$$

a_x^+ , a_y^+ , a_x^- and a_y^- are respectively the areas of the positive and negative reinforcement in the x and y directions, h is the height of the slab, f_y is the steel bar yield characteristic stress, f_c is the reduced compression resistance of the concrete ($f_c = 0.45 f_{ck}$) and f_{ck} is the characteristic resistance of the concrete.

The Equations (4) and (5) are the equations of the surface of Johansen. The Equations (6) and (7) represent a surface with constant height, equal to the value of the ultimate moment of torsion of Johansen reduced by the coefficient k_{xy} , along the generatrix whose the projection makes an angle of 45° with the m_x and m_y axes of the surface of Johansen. The ultimate moment of torsion is obtained from the surface that supplies the smallest value. The surface proposed by Velasco is presented as follows:

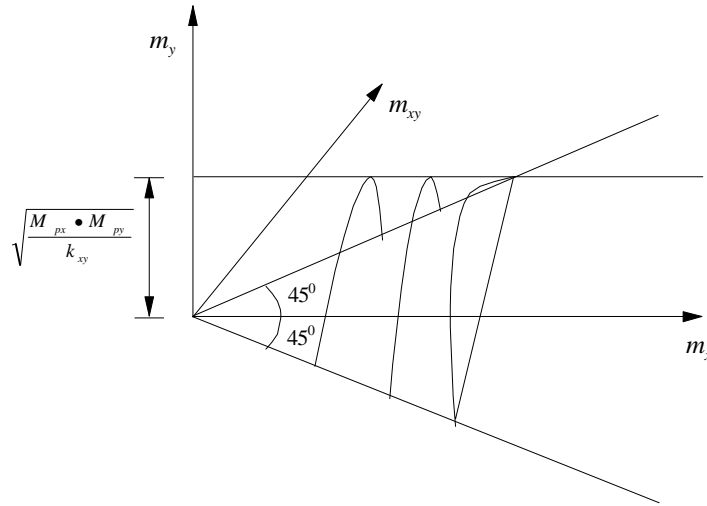

Figure 3 – Revised Surface.

3. OPTIMUM DESIGN USING MATHEMATICAL PROGRAMMING

The design is made here for each point of the slab in function of the applied resultants forces at the point. The resultants forces determination is made by the finite element method with the hypothesis of linear elastic behavior.

To design is to quantify values of the reinforcement so that the solicitation does not surpass the resistance in a certain structural element. Optimum design is the determination of values such as to turn minimum the difference between the resistance and the solicitation in a certain structural element.

In the reinforced concrete slabs, the design is made in way of guaranteeing that at any point of the slab the resultants forces m_x , m_y and m_{xy} be located on or inside of the adopted resistance surface.

In the design of reinforced concrete slabs, the positive and negative ultimate resistant moments can be considered as equal to the product of the “lever arm” (z) by the project stress in the reinforcement (σ_s) and by the areas of the positive and negative reinforcement respectively. This way, all of them should be larger or equal to zero. Besides, the ultimate resistant moments should be larger than every resultants moments so that the yield surface includes these moments. The influence of the double reinforcement being despised, the positive and negative ultimate resistant moments in the x and y directions are presented respectively as follows:

$$M_{px}^+ = a_x^+ z_x^+ \sigma_{sx}^+ \quad (11)$$

$$M_{py}^+ = a_y^+ z_y^+ \sigma_{sy}^+ \quad (12)$$

$$M_{px}^- = a_x^- z_x^- \sigma_{sx}^- \quad (13)$$

$$M_{py}^- = a_y^- z_y^- \sigma_{sy}^- \quad (14)$$

The areas of the positive and negative reinforcement in the two directions are determined from Eqs. (11), (12), (13) and (14). The lever arm (z) and the project stress in the reinforcement (σ_s) are directly determined by solving the equilibrium equations in the ultimate limit state for a rectangular section simply reinforced subjected to a simple flexion,

and using the rectangular diagram for the concrete stresses and the project stresses diagram for the steel (Fusco, 1986). For obtaining (σ_s) , different diagrams of project stresses are used for the CA-25, CA-32, CA-40A, CA-50A, CA-60A, CA-40B, CA-50B and CA-60B steels. The concept of minimum reinforcement foreseen in the brazilian NBR-6118 norm (ABNT, 1978) is also included in the program of optimum design.

The optimum design is arrived at by using mathematical programming. The mathematical programming problem for the optimum design is presented as follows.

$$\begin{aligned}
 \min \quad & f(M_{px}^+, M_{py}^+, M_{px}^-, M_{py}^-) = M_{px}^+ + M_{py}^+ + M_{px}^- + M_{py}^- \\
 \text{subject to} \quad & \pi(\sigma) \leq 0 \\
 & M_{px}^+ \geq \max(0, m_{xi}); M_{py}^+ \geq \max(0, m_{yi}); M_{px}^- \geq |\min(0, m_{xi})|; M_{py}^- \geq |\min(0, m_{yi})|
 \end{aligned} \tag{15}$$

In this work, two resistance criteria are used: the criterion of Johansen and the criterion of Velasco. In both criteria the mathematical programming problem results in a problem of non-linear programming with restrictions. As the objective function as the restrictions of this problem are non-linear. In this work, the Interior Points Method algorithm is used (Herskovits, 1995) to solve the mathematical programming problem indicated by Eq. (15). One of the advantages of this algorithm in relation to others is that it has been shown more efficient (Herskovits, 1995) for solving the Kuhn-Tucker equations of the problem which means to solve directly a system of non-linear equations.

4. INTERIOR POINTS METHOD

The Interior Points Method is proposed by Herskovits (Herskovits, 1995). This method can be applied for mathematical programming problems with a non-linear objective function and non-linear restrictions. To solve this mathematical programming problem, the algorithm uses its Kuhn-Tucker conditions. The initial point should be a point inside the viable area. This algorithm generates a sequence of points inside this area until the convergence to the optimum solution. The implemented algorithm demonstrated to be simple, robust and efficient. It does not involve penalty functions, active group or subproblems of sequential quadratic programming. In general lines, the algorithm just needs to solve two linear systems with the same matrix in each interaction, and to accomplish a linear search without an excess precision.

Consider the following mathematical programming problem:

$$\begin{aligned}
 \min \quad & f(x) \\
 \text{subject to} \quad & g(x) \leq 0
 \end{aligned} \tag{16}$$

The Lagrangean function of this problem is presented as follows:

$$L(x, \lambda) = f(x) - \lambda^T g(x) \tag{17}$$

The Kuhn-Tucker conditions are presented as follows:

$$\nabla f(x) + \nabla g(x)\lambda = 0; G(x)\lambda = 0; (\lambda \geq 0); g(x) \leq 0 \quad (18)$$

Where G is the diagonal matrix with $G_{ii} \equiv g_i$. The Newton-Rapshon method is used to solve the system of non-linear equations described by Eq. (18).

$$\begin{bmatrix} H(x^k, \lambda^k) & \nabla g(x^k) \\ \Lambda^k \nabla g^t(x^k) & G(x^k) \end{bmatrix} \begin{bmatrix} x^{k+1} - x^k \\ \lambda_0^{k+1} - \lambda^k \end{bmatrix} = - \begin{bmatrix} \nabla f(x^k) + \nabla g(x^k)\lambda^k \\ G(x^k)\lambda^k \end{bmatrix} \quad (19)$$

Where (x^k, λ^k) is the initial point and $(x^{k+1}, \lambda_0^{k+1})$ is an estimate of the solution. For the determination of a new viable point a linear search is accomplished in the direction $d^k = x^{k+1} - x^k$. The detailed steps of the algorithm can be found in Herskovits (1995).

5. EXAMPLE

The optimum design at points of reinforced concrete slabs is made in two points of a rectangular slab with two simply supported edges and two built-in edges submitted to a uniformly distributed load equal to $q = 15.4 \frac{KN}{m^2}$ (Points A and B), and at point of a square slab simply supported by three of its vertexes submitted to two load cases: a concentrated load on its free vertex equal to $P = 28KN$ (Point C) and a concentrated load on its free vertex equal the $P = 20KN$ (Point D). The rectangular slab has the side in the x direction equal to $7m$ and the side in the y direction equal to $5m$. A side in the x direction and a side in the y direction are built-in in the rectangular slab. The side of the square slab is equal to $5m$. The square slab is submitted to a constant torsion state in both load cases.

The thickness of the slabs is equal to $h = 0.12m$. The useful height of the slabs in the x and y directions are respectively equal to $d_x = 0.105m$ and $d_y = 0.1m$. The elasticity modulus of the concrete is equal the $E_c = 2.94015 \times 10^4 Mpa$, the elasticity modulus of the steel is equal to $E_s = 2.1 \times 10^5 Mpa$, the Poisson coefficient of the concrete is equal to $\nu = 0.2$, the characteristic resistance of the concrete is equal to $f_{ck} = 21MPa$, the characteristic resistance of the steel is equal to $f_{yk} = 500MPa$. The steel used in the reinforcement is the CA-50A one.

The resultants moments were obtained through a linear elastic analysis with the use of the finite element method. The used element was the isoparametric one with eight nodes, Q8 (Cook, 1981). The used meshes were a bilinear-quadrilateral mesh (14x10) in the rectangular slab and a bilinear-quadrilateral mesh (10x10) in the square slab.

Table 1 presents the plastification moments and the reinforcement rates obtained by using the optimum design program with the yield criterion of Johansen and the yield criterion proposed by Velasco. The rectangular slab with its contour conditions and its applied load and the squared slab with its contour conditions and its two load cases are presented as follows.

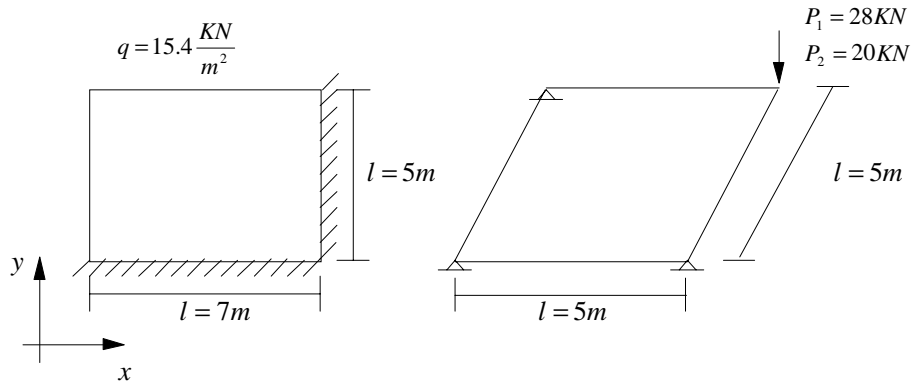

Figure 4 – Rectangular and square slab.

Table 1. Plastification moments and reinforcement rates.

Solicitations $\left(\frac{KN\ m}{m}\right)$		Points				
		A	B	C	D	
Plastification Moments $\left(\frac{KN\ m}{m}\right)$ and Restrictions	m_x	-19.22	-0.77	0.0	0.0	
	m_y	-10.73	-0.65	0.0	0.0	
	m_{xy}	0.0	12.55	14.26	10.19	
	Johansen	M_{px}	0.0	11.78	14.26	10.19
		M_{nx}	19.22	13.32	14.26	10.19
		M_{py}	0.0	11.90	14.26	10.19
		M_{ny}	10.73	13.20	14.26	10.19
		r_1	0.0	0.0	0.0	0.0
		r_2	0.0	0.0	0.0	0.0
	Velasco	M_{px}	0.0	15.27283	20.19093	11.34894
		M_{nx}	19.22	15.33071	20.19093	11.34894
		M_{py}	0.0	15.33012	20.19093	11.34894
		M_{ny}	10.73	15.26786	20.19093	11.34894
		r_1	0.0	-98.8638	-204.326	-24.9603
r_2		0.0	-55.344	-204.326	-24.9603	
r_3		0.0	-0.01412	-0.02107	-0.00453	
r_4		0.0	-0.01154	-0.02107	-0.00453	
Reinforcement Rates $\left(\frac{m^2}{m}\right)$	Johansen	a_{px}	0.0	2.69864×10^{-4}	3.30051×10^{-4}	2.31946×10^{-4}
		a_{nx}	4.54562×10^{-4}	3.07084×10^{-4}	3.30051×10^{-4}	2.31946×10^{-4}
		a_{py}	0.0	2.87825×10^{-4}	3.48713×10^{-4}	2.44568×10^{-4}
		a_{ny}	2.58153×10^{-4}	3.21190×10^{-4}	3.48713×10^{-4}	2.44568×10^{-4}
	Velasco	a_{px}	0.0	3.55014×10^{-4}	4.79634×10^{-4}	2.59534×10^{-4}
		a_{nx}	4.54562×10^{-4}	3.56447×10^{-4}	4.79534×10^{-4}	2.59534×10^{-4}
		a_{py}	0.0	3.768×10^{-4}	5.08474×10^{-4}	2.73808×10^{-4}
		a_{ny}	2.58153×10^{-4}	3.75158×10^{-4}	5.08474×10^{-4}	2.73808×10^{-4}

Where the expressions r_1 , r_2 , r_3 and r_4 represent the restrictions ($\pi(\sigma)$) of the mathematical programming problem presented by Eq. (15) and are presented as follows:

$$r_1 = m_{xy}^2 - (M_{px}^+ - m_x) \times (M_{py}^+ - m_y) \quad (20)$$

$$r_2 = m_{xy}^2 - (M_{px}^- + m_x) \times (M_{py}^- + m_y) \quad (21)$$

$$r_3 = m_{xy}^2 \{ (M_{px}^+ + M_{py}^+) - (m_x + m_y) \}^2 - (M_{px}^+ - m_x)(M_{py}^+ - m_y) \times \frac{4M_{px}^+ M_{py}^+}{(k_{xy}^+)^2} \quad (22)$$

$$r_4 = m_{xy}^2 \{ (M_{px}^- + M_{py}^-) + (m_x + m_y) \}^2 - (M_{px}^- + m_x)(M_{py}^- + m_y) \times \frac{4M_{px}^- M_{py}^-}{(k_{xy}^-)^2} \quad (23)$$

6. CONCLUSION

In agreement with the results presented in table 1, for point A, the optimum design using the yield criterion of Velasco supplies the same values of the optimum design using the yield criterion of Johansen. This happens, because there is not a moment of torsion at this point and consequently the yield criterion of Johansen and of Velasco coincide. For point B, the optimum design using the yield criterion of Velasco supplies larger values than the optimum design using the yield criterion of Johansen. This happens, because, at this point, the value of the moment of torsion is significant in relation to the flexion moments and consequently the surface proposed by Velasco is more restrictive than the surface of Johansen. For point D, the optimum design using the yield criterion of Velasco supplies values lightly larger than the optimum design using the yield criterion of Johansen. This happens, because, at this point, there is only moment of torsion and consequently the surface proposed by Velasco is more restrictive than the surface of Johansen. The difference among the values of the plastification moments supplied at point D by the two criteria is equal to 11.37%. This small difference is due to the fact that the moment of torsion is not very elevated at this point. For point C, the optimum design using the yield criterion of Velasco supplies much larger values than the optimum design using the yield criterion of Johansen. This happens, because, at this point, there is only moment of torsion and consequently the surface proposed by Velasco is more restrictive than the surface of Johansen. The difference among the values of the plastification moments supplied at point C by the two criteria is equal to 41.6%. This great difference is due to the elevated value of the moment of torsion at this point.

REFERENCES

- ABNT, NBR-6118 – Projeto e Execução de Obras de Concreto Armado, Rio de Janeiro, Brasil, Associação Brasileira de Normas Técnicas, 1978.
- Cook, R.D., *Concepts and Applications of Finite Element Analysis*, J. Wiley & Sons, 1981.
- Fusco, P.B., *Estruturas de Concreto Armado – Solicitações Normais*, Rio de Janeiro, Brasil, Guanabara Dois S.A., 1986.
- Herskovits, J., *A View on Nonlinear Optimization*, Advances in Structural Optimization, pp 71-116, 1995.

Johansen, K.W., Linhas de Ruptura: Teoria e Prática, Rio de Janeiro, Brasil, Ao livro técnico S.A., Tradução de Mascu, J., 1962.

Marti, P. Leesti, P. & Khalifa, W.U., *Torsion Test on Reinforced Concrete Slab Elements*, Journal of Structural Engineering, Vol. 113, n° 5, 1987.

Massonet, C.E. & Save, M.A., Cálculo Plástico de Las Construciones, Barcelona, Vol. 2, 1966

Velasco, M.S.L., Vaz, L.E. & Afonso, S.M.B., Avaliação da Superfície de Colapso de Johansen Através de um Modelo Numérico, XV CILAMCE, Vol. 2, pp 1376-1385, 1994.